

HillhouT

BLOKHUT MADEIRA GRAND MET SHINGLEDAK

385x275 cm

ART. NR./REF. 713210

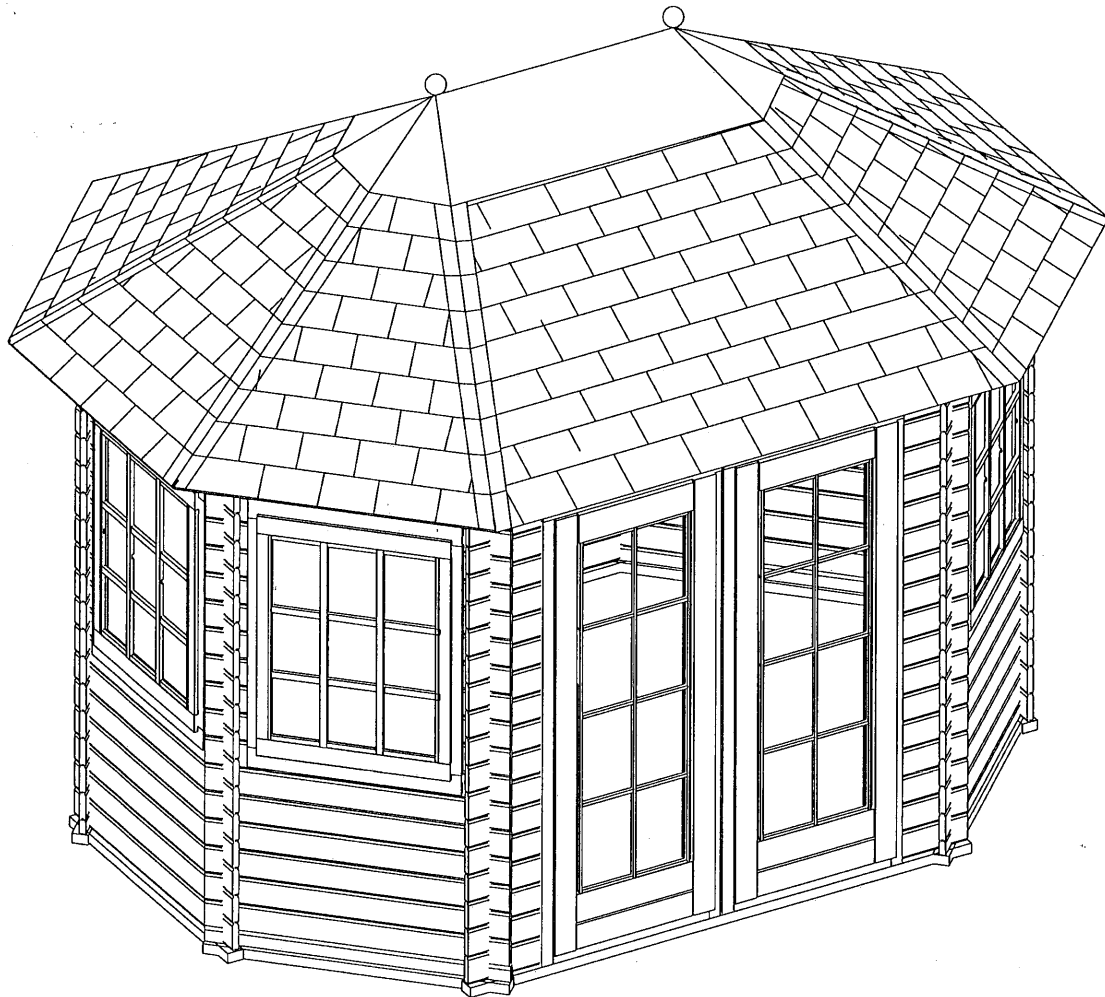

MONTAGE HANDLEIDING / MONTAGEANLEITUNG / NOTICE DE POSE
BUILDING INSTRUCTIONS / ISTRUZIONI PER IL MONTAGGIO / INSTRUCCIONES DE MONTAJE

NL BELANGRIJKE TIPS:

- Lees eerst deze opbouwhandleiding volledig door.
- Boor de schroefverbindingen zoveel mogelijk voor (gebruik de juiste boormaat).
- Een goede ventilatie van de blokhut is noodzakelijk (Zet deur en/of raam regelmatig open).
- Hillhout blokhutten worden blank afgeleverd. Voor of na het plaatsen moet u ze daarom wel schilderen of beitsen met een vochtregulerende beits, zowel aan de binnen- als aan de buitenkant (niet over hang- en sluitwerk schilderen). Gebruik geen lak, want hiermee sluit u het hout af, zodat eventueel vocht dat in het hout zit er niet uit kan. Ook is het aan te raden de blokhut eerst met een houtveredelingsmiddel te behandelen. Raadpleeg voor meer informatie uw verfvakman.
- Om te voorkomen dat vocht tussen de grondregels en de fundering doordringt, kunt u hier- tussen siliconenkit aanbrengen, of na de opbouw langs de buitenzijde.
- Door de natuurlijke werking van hout kan uw blokhut in de hoogte uitzetten of krimpen.
- U kunt aan maximaal 2 wandbalklagen plankdragers o.i.d. bevestigen. Beter is het echter om een losse wandstelling te gebruiken (dit i.v.m. het werken van het hout).
- Indien de blokhut een luifel heeft, dient de afvoer van de goot bij de voorwand te worden geplaatst.
- Bij het schilderen dient u het glas uit raam en deur te verwijderen om ook de sponning te kunnen schilderen. LET OP: raam helemaal naar boven draaien en dan eruit pakken! De glaslatten aan de buitenkant moeten worden afgekit.
- Onderhoud regelmatig het hang- en sluitwerk.
- Uw blokhut is een waardevol bezit. Denk daarom aan het eventueel verzekeren hiervan.

D WICHTIGE HINWEISE:

- Lesen Sie diese Bauanleitung erst aufmerksam durch.
- Bohren Sie möglichst viele Schraubverbindungen vor (und benutzen Sie die jeweils richtige Bohrergröße).
- Eine gute Durchlüftung des Blockhauses ist notwendig (öffnen Sie die Fenster und Tür regelmäßig).
- HillHout Blockhäuser werden unbehandelt geliefert. Vor oder nach dem Aufstellen müssen Sie sie daher sowohl an der Innen- als auch an der Außenseite mit einem feuchtigkeitsregulierenden Holzschutz behandeln (nicht die Beschläge anstreichen). Benutzen Sie keinen Lack, da Sie damit das Holz abdichten, so dass Feuchtigkeit, die sich möglicherweise in dem Holz befindet, nicht entweichen kann. Es ist ebenfalls empfehlenswert, das Blockhaus erst mit einem Holzveredlungsmittel zu behandeln. Für weitergehende Information ziehen Sie bitte einen Farbenfachmann zu Rate.
- Um zu verhindern, dass Feuchtigkeit zwischen den Grundbalken und dem Fundament eindringt, können Sie die Zwischenräume mit Silikon abdichten.
- Durch das natürliche Arbeiten des Holzes kann Ihr Blockhaus sich in der Höhe ausdehnen oder schrumpfen.
- Dieses Arbeiten des Holzes, sollten Sie bei der Anbringung von Regalen u.ä. berücksichtigen. Wir empfehlen daher freistehende Regale zu verwenden.
- Hat das Blockhaus ein Vordach, soll das Fallrohr der Regenrinne an der Frontseite platziert werden.
- Beim Anstreichen bitte die Glasscheiben aus Fenster und Tür entfernen um auch die Falze anstreichen zu können. ACHTUNG: das Fenster völlig hochdrehen und aus dem Fensterrahmen nehmen, dann erst die Scheibe herausnehmen! Die Glaslatten an der Außenseite bitte mit Silikon-Kleber abdichten.
- Pflegen Sie die Beschläge regelmäßig.
- Ihr Blockhaus ist ein wertvoller Besitz, denken Sie daher an eine eventuelle Versicherung

F CONSEILS IMPORTANTS :

- Lisez tout d'abord cette notice d'un bout à l'autre.
- Egalisez tout d'abord la surface. Utilisez le niveau.
- Pré percez autant que possible les assemblages à visser.
- Une bonne ventilation de la maisonnette est indispensable. Ouvrez régulièrement portes et fenêtres.
- Les maisonnettes Hillhout sont livrées non traitées.
- Le traitement, indispensable, peut intervenir soit avant, soit après le montage, aussi bien à l'extérieur qu'à l'intérieur.
- Il vous suffit de passer la lasure de votre choix; vous pouvez également la peindre; n'utilisez pas de laque ni de vernis. La peinture micro poreuse est conseillée
- Appliquez un joint silicone pour éviter la pénétration de l'humidité entre la base et la fondation (avant ou après le montage).
- Il est normal que le bois travaille, vous pourrez éventuellement constater dilatations et rétrécissements en fonction des périodes de l'année.
- Si votre maisonnette est équipée d'un auvent, il faut poser le tuyau de la gouttière côté façade.
- Si vous désirez peindre la maisonnette, il faut retirer le verre de la porte et de la fenêtre (en enlevant les parecloses) pour peindre également la rainure. Appliquez un joint silicone sur les parecloses côté extérieur.
- Entretenez régulièrement la serrure.



GB IMPORTANT TIPS:

- Please read these building instructions carefully before building.
- The base/foundation for your cabin must be level and flat.
- Pre-drill as much as possible the holes for the screws (use the correct drill-size).
- Good ventilation of the log cabin is necessary (open door and/or window frequently).
- Hillhout log cabins are supplied UNTREATED. Before painting or staining the cabin we advise you to treat the timber first with a wood preservative (use a well known quality brand). For more information, please contact your paint specialist. You can then paint or stain your cabin before or after building, inside as well as outside with a moisture regulating product (don't paint over the latch and bolt + hinges). Don't use a lacquer as this will "close" the structure of the wood and humidity can't get out.
- To prevent humidity from entering between the foundation beams and your foundation, please put silicone-lute in between. After having built the log cabin, you can also put the silicone-lute along the outside.
- Because of the natural working of wood, your log cabin can expand or shrink in height.
- Should you want to fit any shelves (for books, for instance), you can fix these to 2 wall logs at a maximum. Because of the working of the wood it will be better, however, to use a separate rack against the wall.
- You will need at least 3 people to build the sectional roof.
- In the case of your log cabin having a front extension, the gutter's drain should be placed at the front wall.
- Please remove the glazing from door and window before painting, to be able to paint the rabbets as well. ATTENTION: turn window fully upwards in order to take it out of its frame and then carefully remove the glass! Apply silicone-lute to cover the space between the glass-laths and the glazing on the outside of the window.
- Frequently maintain the latch and bolt + hinges.
- Your log cabin is a valuable possession. Perhaps you should have it insured.



I AVVERTENZE IMPORTANTI:







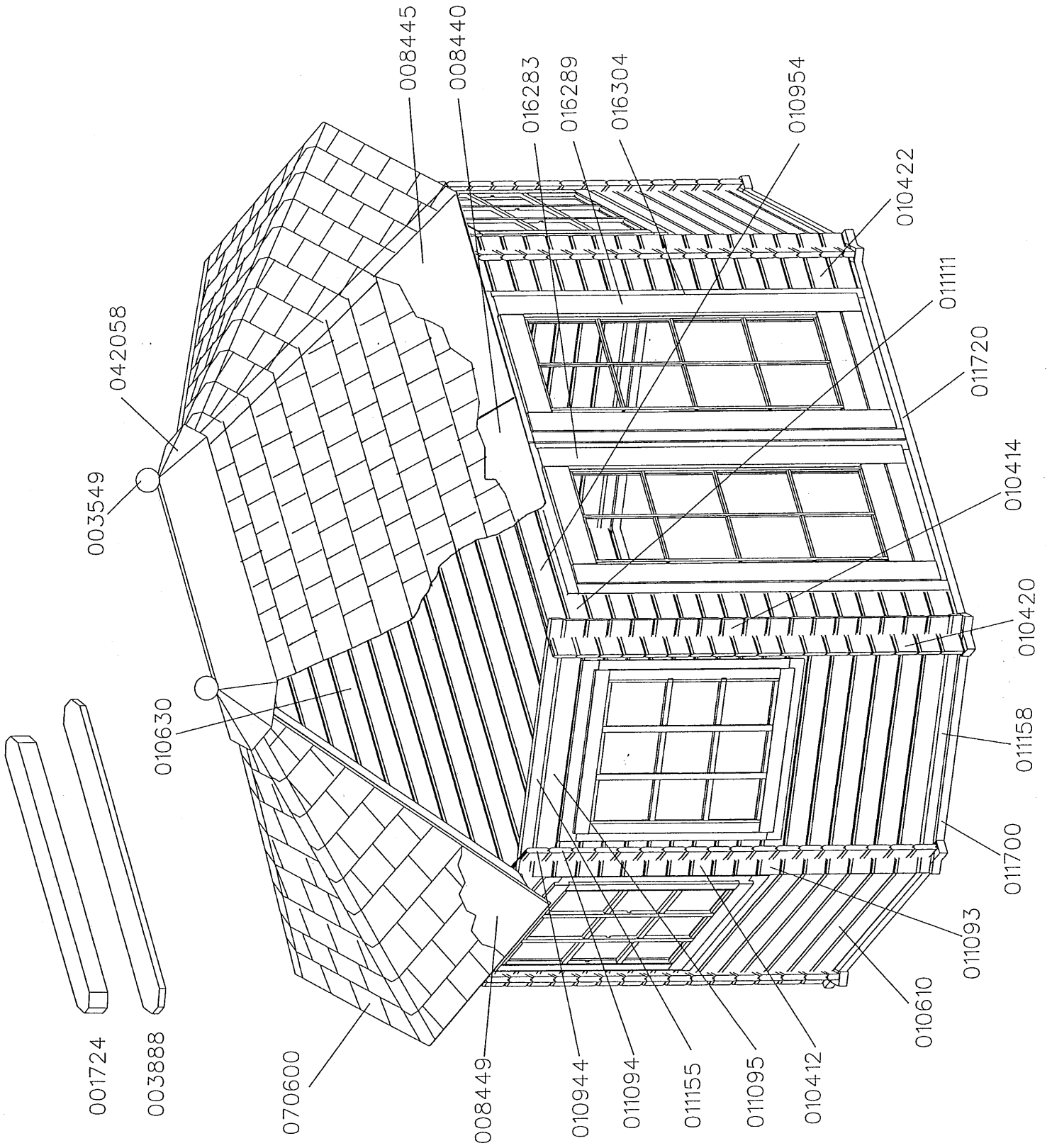

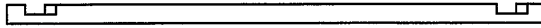
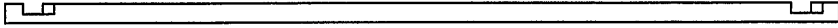

- Leggere innanzitutto completamente queste istruzioni di montaggio.
- Praticare in precedenza per quanto possibile i fori di giunzione (usare la punta con la misura giusta).
- È necessario ventilare la casetta in modo adeguato (aprire con regolarità porte e finestre).
- Le casette Hillhout vengono fornite in materiale non trattato. È pertanto necessario procedere alla verniciatura od all'applicazione di colorante in soluzione acquosa, resistente all'umidità, sia sulle superfici interne che su quelle esterne (non verniciare i serramenti!). Non usare lacche, che coprano ermeticamente il legno, impedendo la fuoriuscita d'eventuale umidità presente in quest'ultimo. Si consiglia inoltre d'impregnare in primo luogo tutti i componenti della casetta con un preparato protettivo. Chiedere informazioni supplementari al proprio rivenditore di vernici specializzato.
- Applicare una colla al silicone per evitare la penetrazione d'umidità fra le traverse d'appoggio al suolo ed il basamento.
- I componenti della casetta possono tendere a dilatarsi od a restringersi in altezza, in seguito alla deformazione naturale del legno.
- È possibile montare staffe per scaffali o simili su al massimo 2 fasce di perline da parete. Convieni tuttavia usare una scaffalatura a se stante (ciò in relazione alla deformazione del legno).
- Se si tratta di una casetta con tettoia frontale, bisogna installare il tubo di scolo alla parete anteriore.
- Prima di pintare, rimuovere il vetro della finestra e la porta per potere pintare anche le scanalature. **ATTENZIONE** : girare la finestra completamente a sopra per potere rimuovere la finestra del suo telaio e poi rimuovere il vetro ! Bisogna incollare i listelli del vetro che si trovano dall'esterno.
- Effettuare regolarmente la manutenzione i serramenti.
- La casetta costituisce un bene di valore. Si consiglia di valutare la possibilità d'assicurarla.

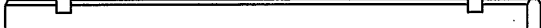
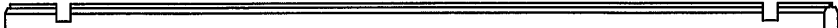
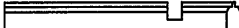
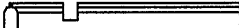
E Sugerencias importantes:

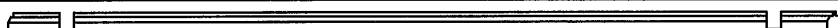
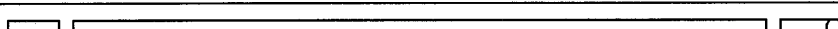
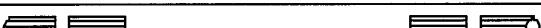
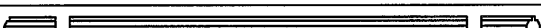
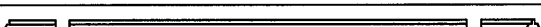



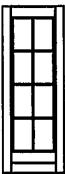

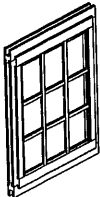
- Lea primero este manual de construcción completamente.
- Preperfore, en lo posible, las uniones con tornillo (use la medida de broca adecuada).
- Es necesario ventilar bien la casita (abra regularmente la puerta).
- Las casitas de madera Hillhout se suministran sin tratar. Por eso, hay que pintarlas o tratarlas con un lasur que regule la humedad, por dentro y por fuera, antes o después de construirlas (¡no pinte los herrajes!). No use laca, ya que así se sella la madera, de modo que la humedad que puede haber en la madera no puede salir. También aconsejamos tratar primero la casita con un producto de preservación de madera. Para más información, consulte a su especialista en pinturas.
- Para evitar que penetre humedad entre las vigas de suelo y los cimientos, puede aplicar silicona entre ellos.
- El alabeo natural de la madera puede causar que su casita se dilate o se contraiga en la altura.
- Puede fijar soportes de estantes, o algo similar, a 2 capas de vigas de pared, como máximo. Mejor es usar una estantería suelta (en relación con el alabeo de la madera).
- Si se trata de una casita con alero, la bajada de aguas del canalón debe ser montada por la parte delantera.
- Antes de pintar, quite el cristal de la ventana y la puerta para poder pintar también las ranuras. **ATENCIÓN** : gire la venta completamente por arriba para sacarla de su marco y después quite el cristal ! Encole los listones de vidriera que se encuentran al exterior.
- Mantenga regularmente los herrajes.
- Su casita es una propiedad valiosa. Piense, por ello, en la posibilidad de asegurarla.

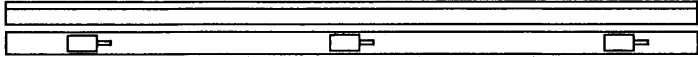
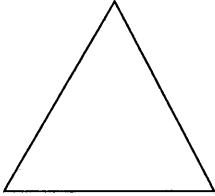
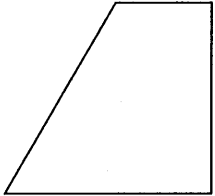
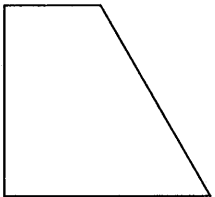
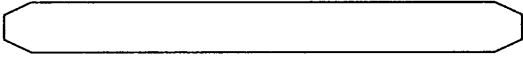

Madeira Grand met shingle dak

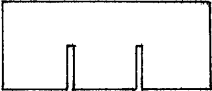
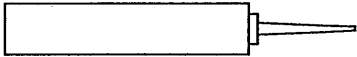
Art. nr.ref			Aantal
011700	1280 mm		6
011720	2390 mm		2
011158	1280 mm		4
010610	1280 mm		60
010630	2390 mm		17
010420	420 mm		16
010422	420 mm		16
010412	190 mm		36
010414	190 mm		36
011111	2390 mm		1
010954	2390 mm		2
011093	1280 mm		2
011094	1280 mm		2
011095	1280 mm		2
011155	1280 mm		4
010944	1280 mm		2
016283			1
016289			1
016320			2
016316			2

Madeira Grand met shingle dak

Art. nr.ref			Aantal
016304			1
008449			6
008440			2
008445			2
001724	1150 mm		1
003888	1185 mm		1
042058	350x1480 mm		1
070600			126
075059			1
013514	945 mm		8
013525	1610 mm		2
003549	ø 140 mm		2

+ divers bevestigingsmateriaal
 + diverses Befestigungsmaterial
 + matériel de fixation divers
 + various fixing materials
 + diverso materiale fissaggio
 + Materiales de fijación diversos

1

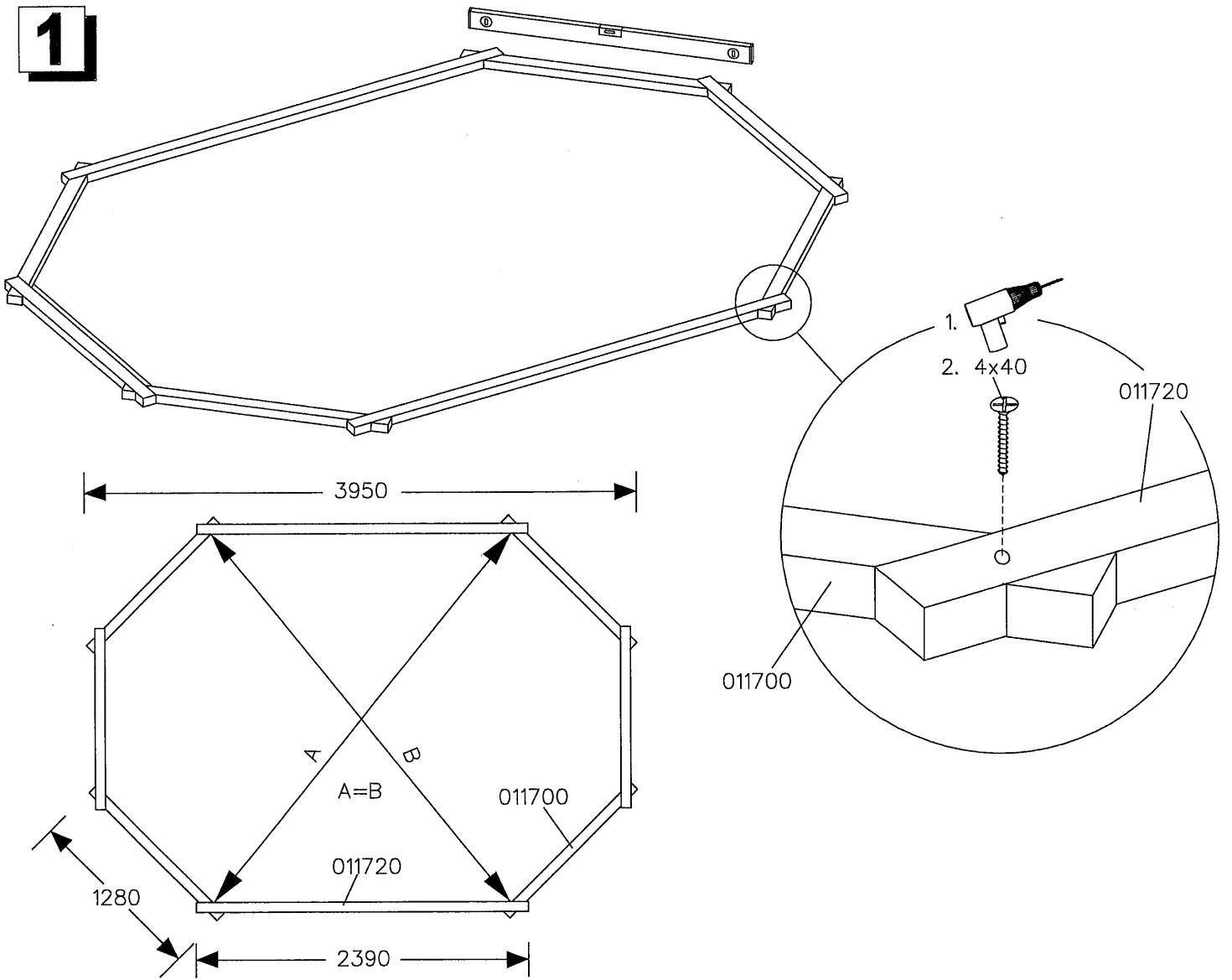

2

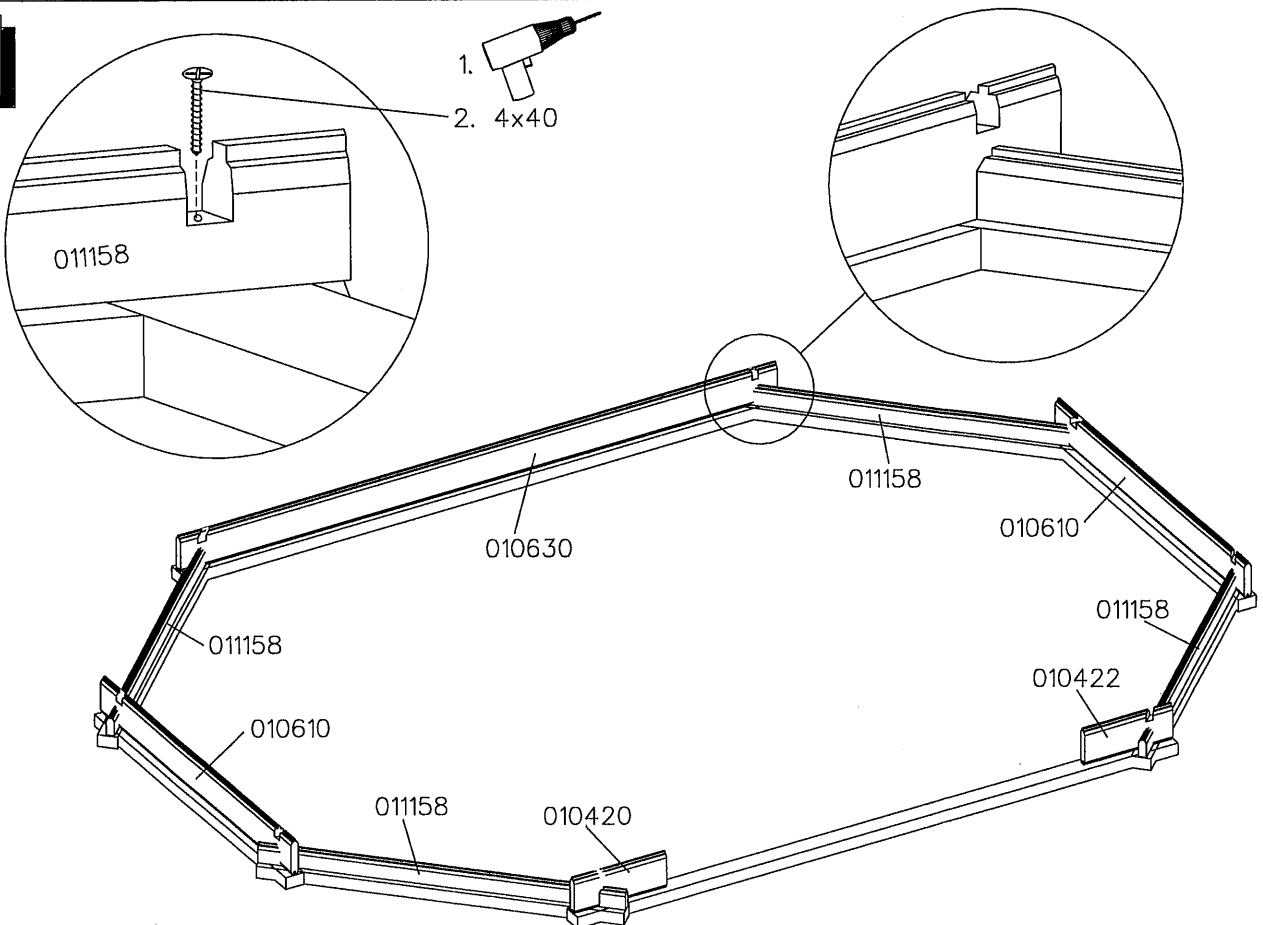

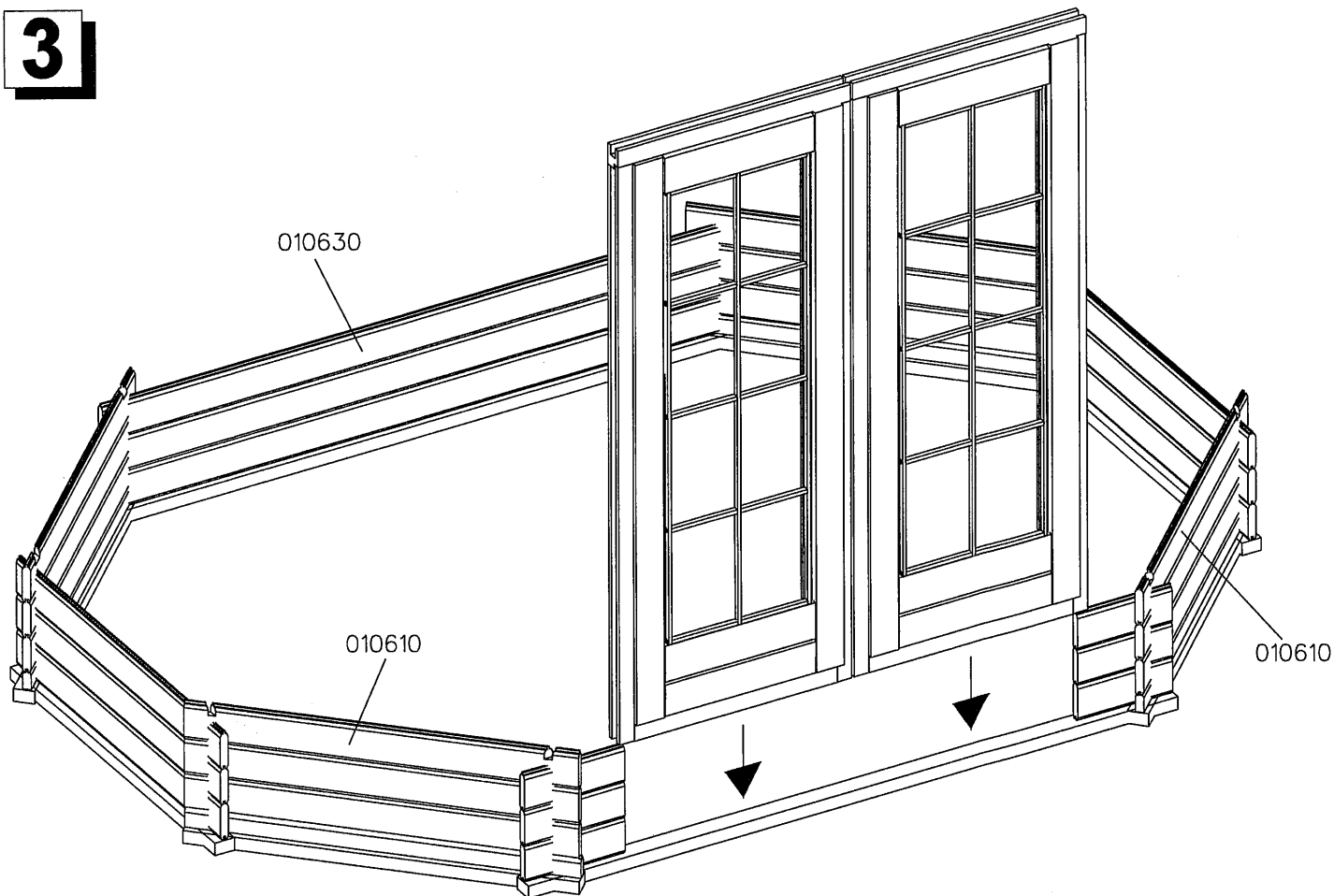

3

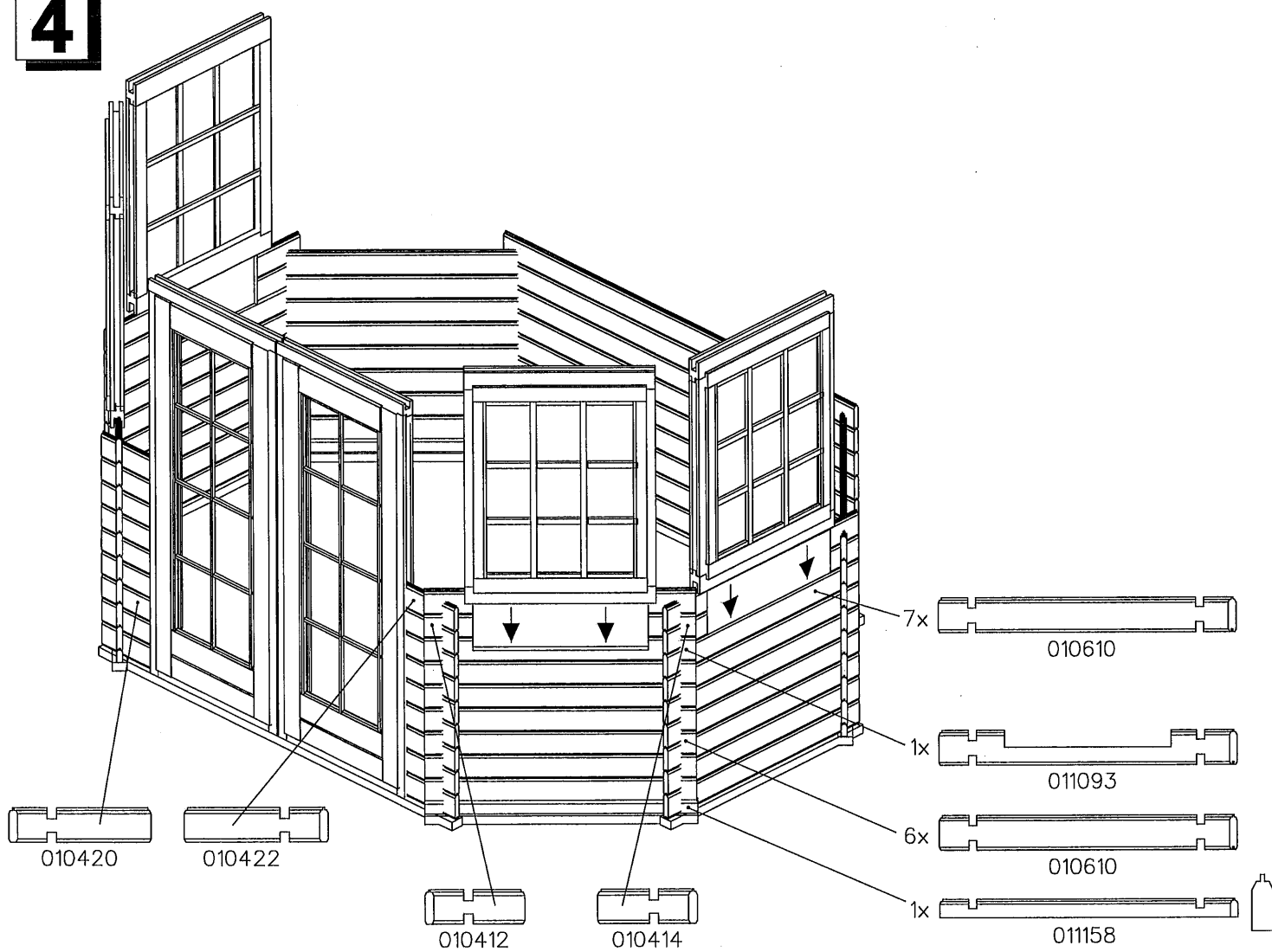

4



5

- 1. 
- 2. 4x60 

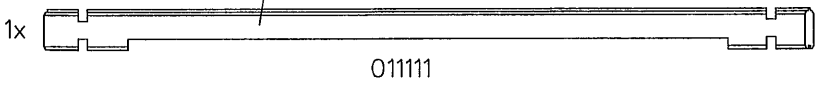
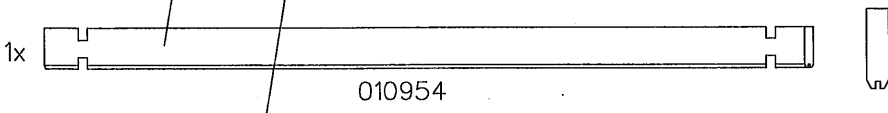
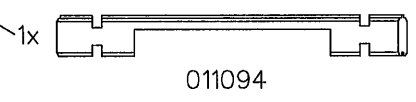
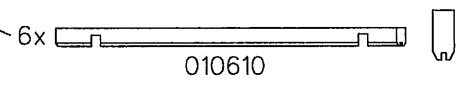
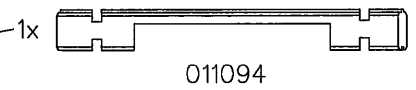
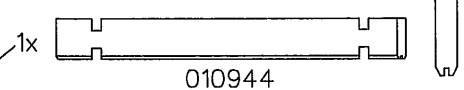
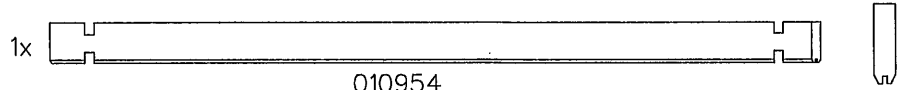
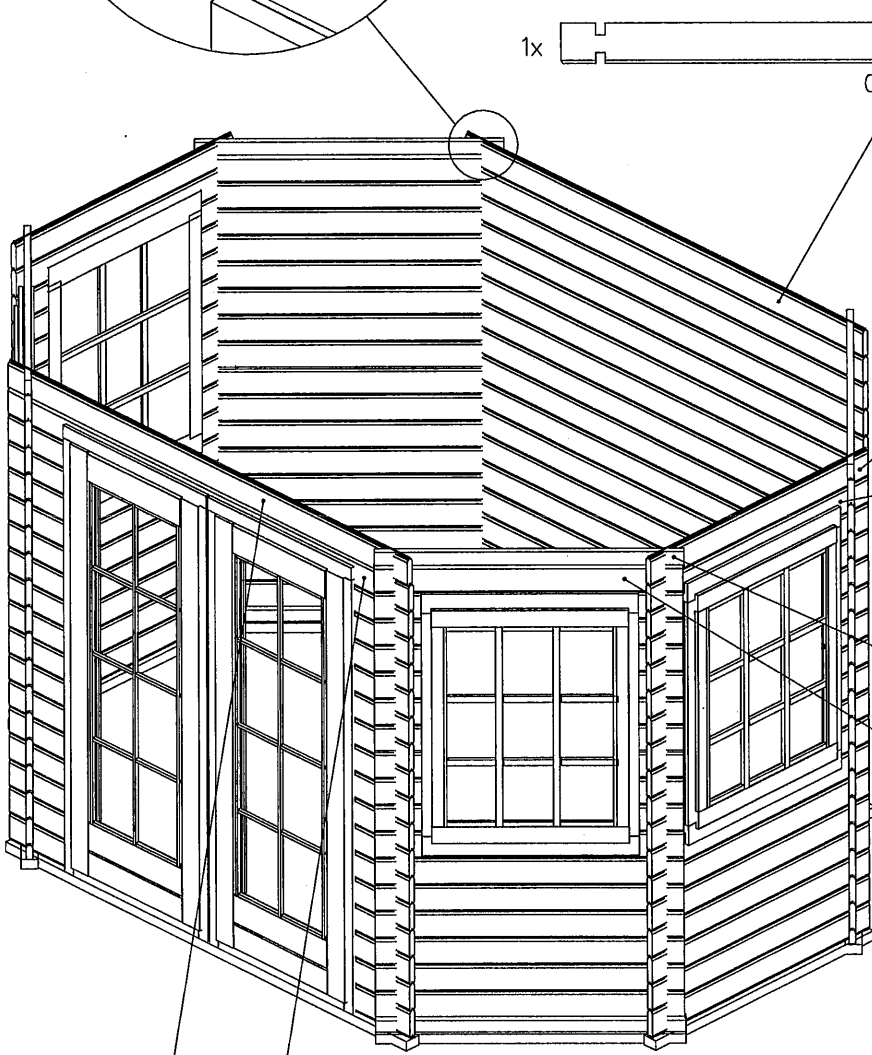
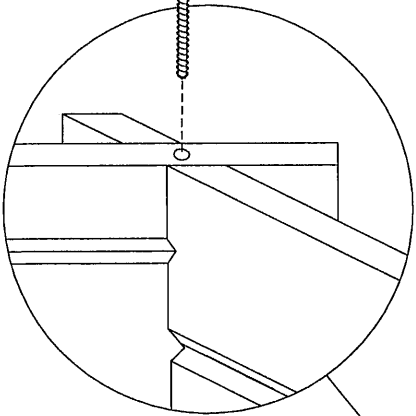

6

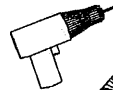
1. 
2. 4x60

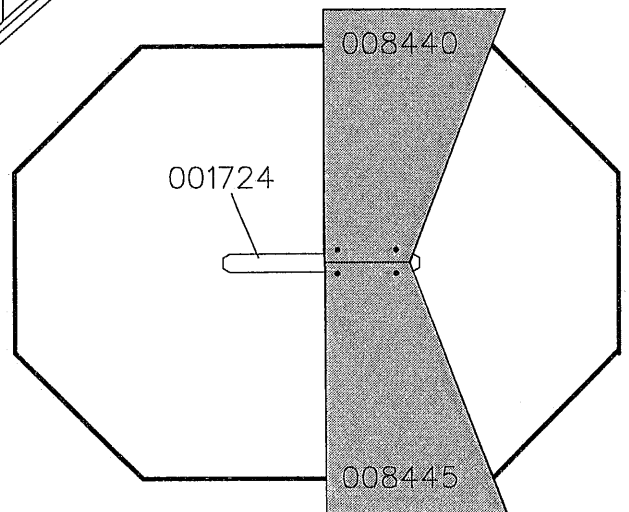
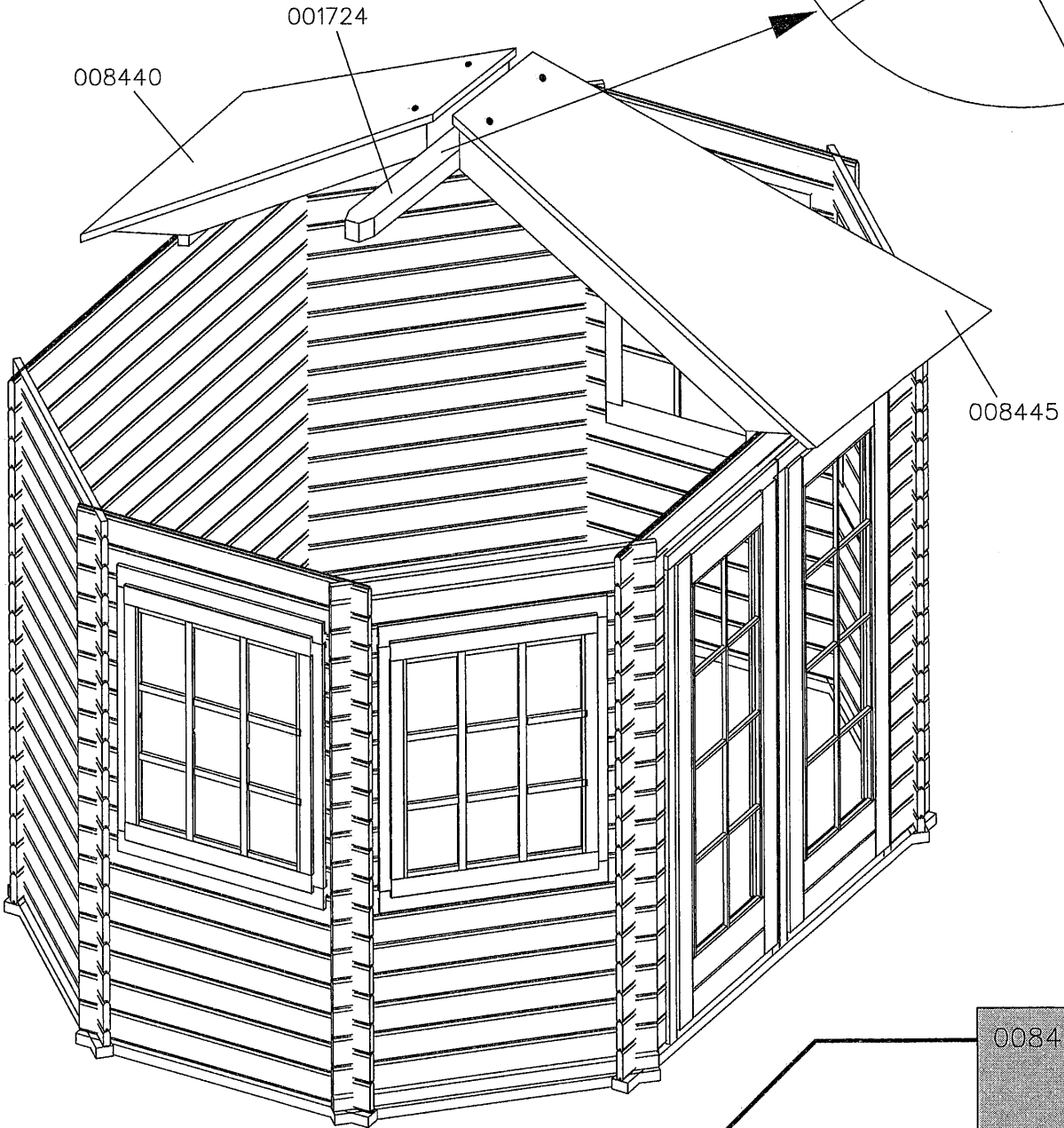
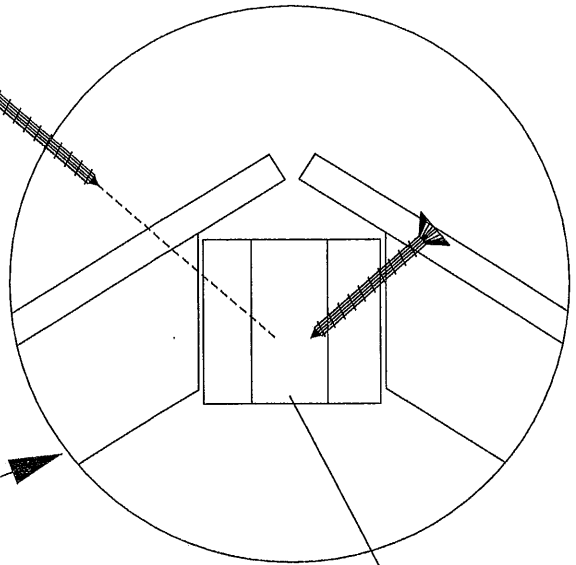

7

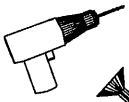
- 1. 
- 2. 4x60

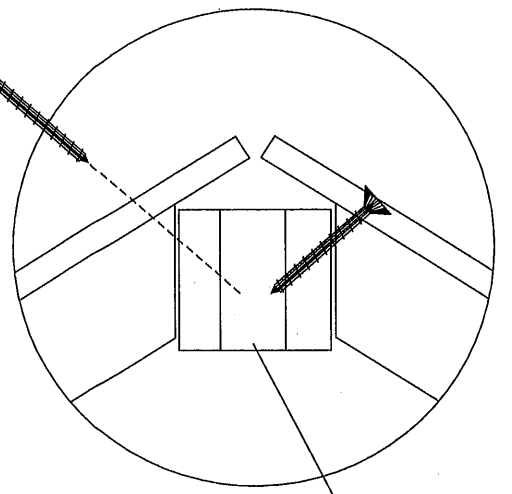

001724

008445

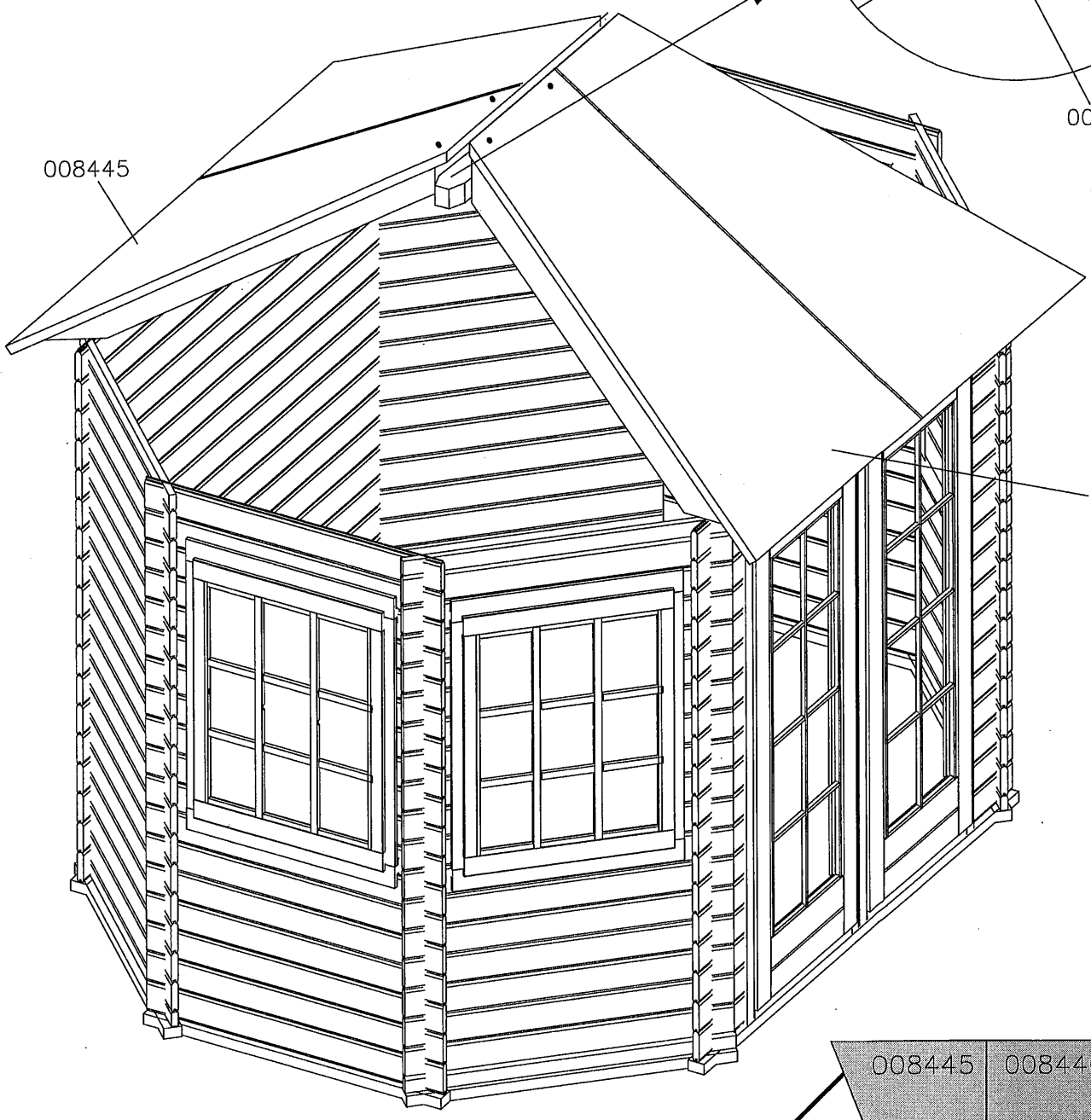

008440

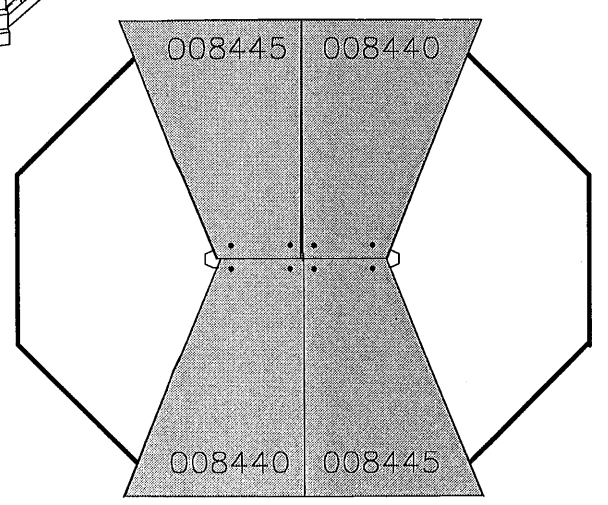

8

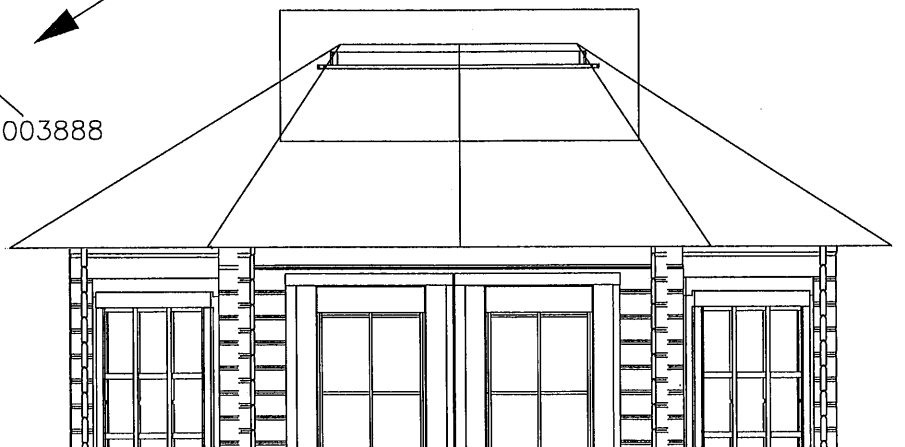
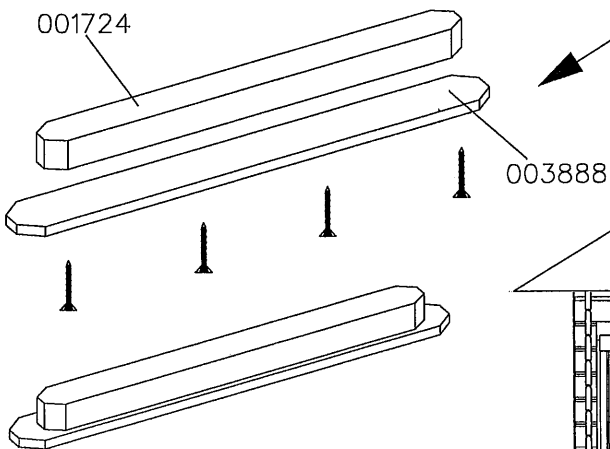
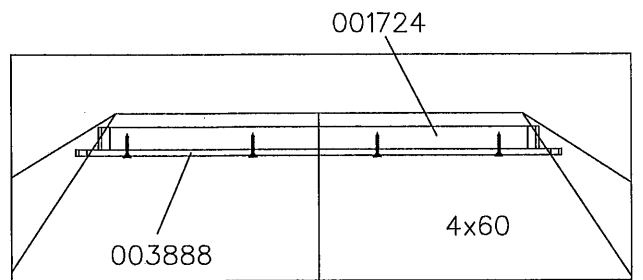
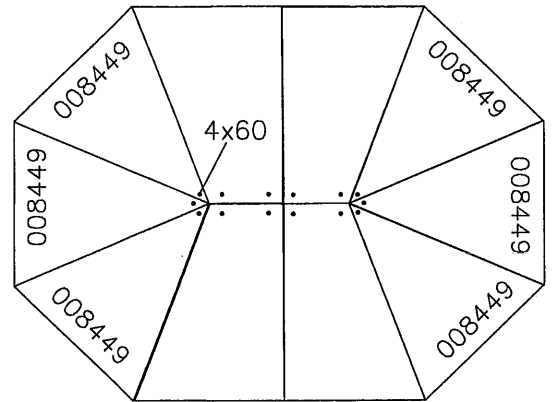
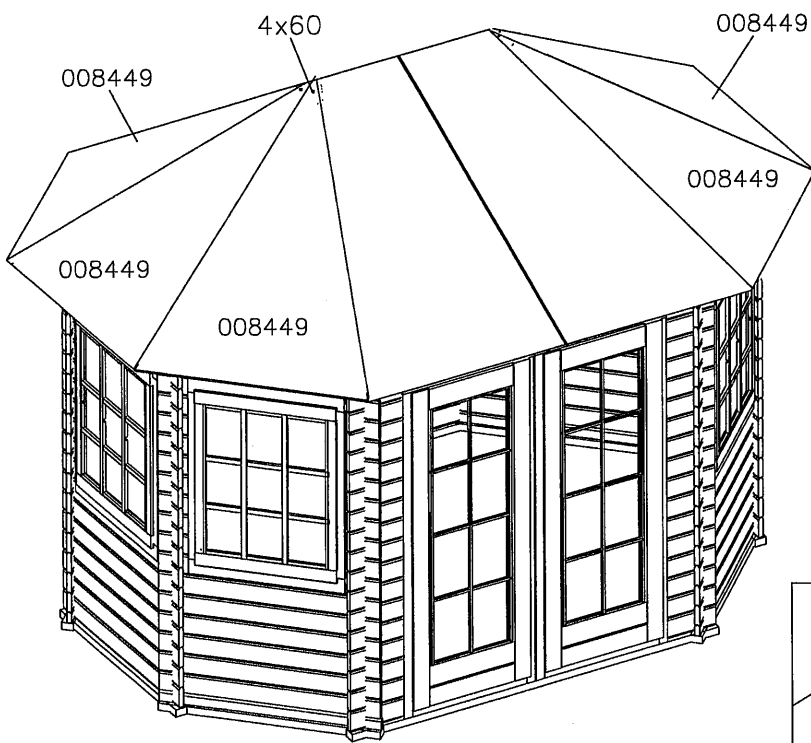
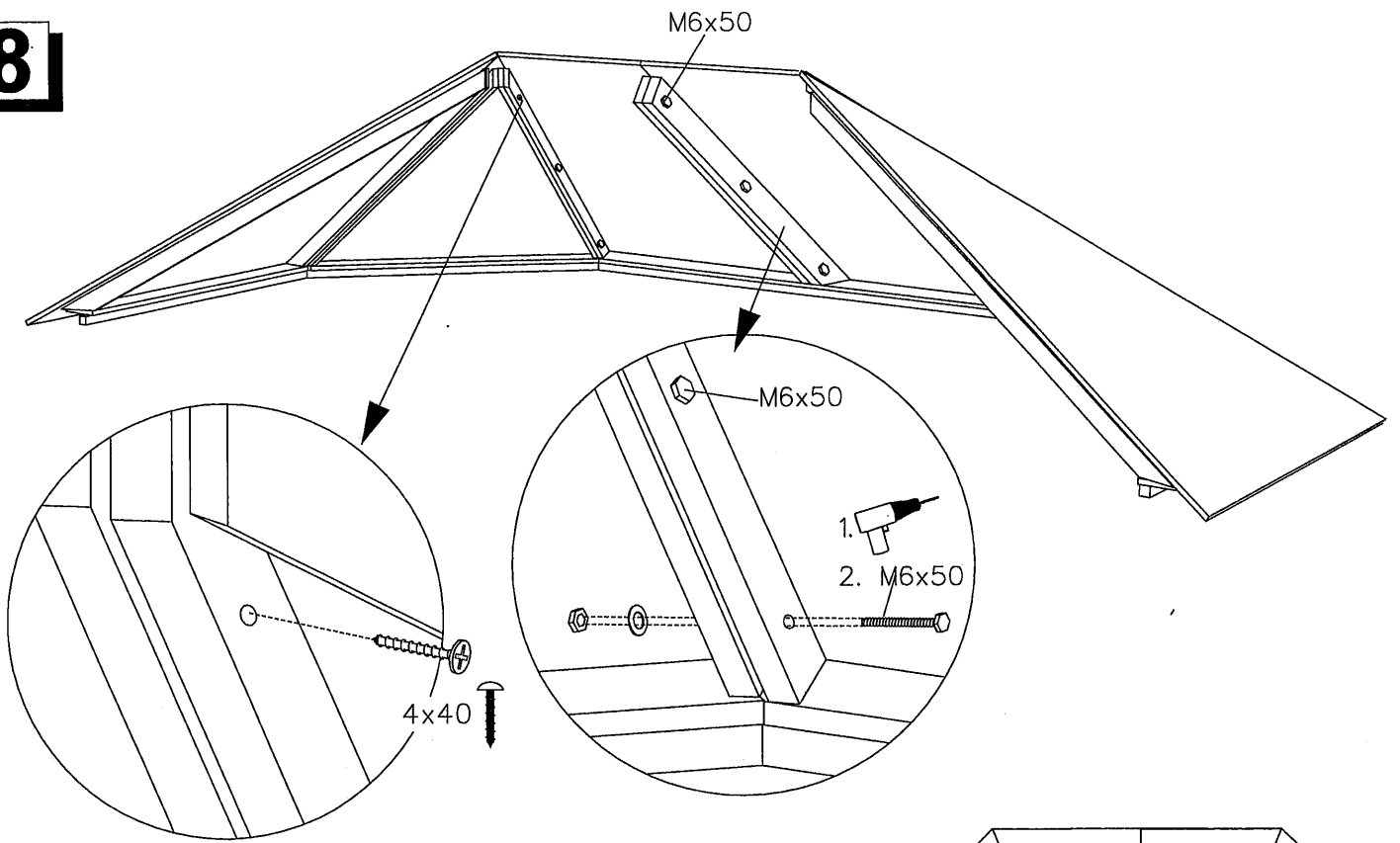

9

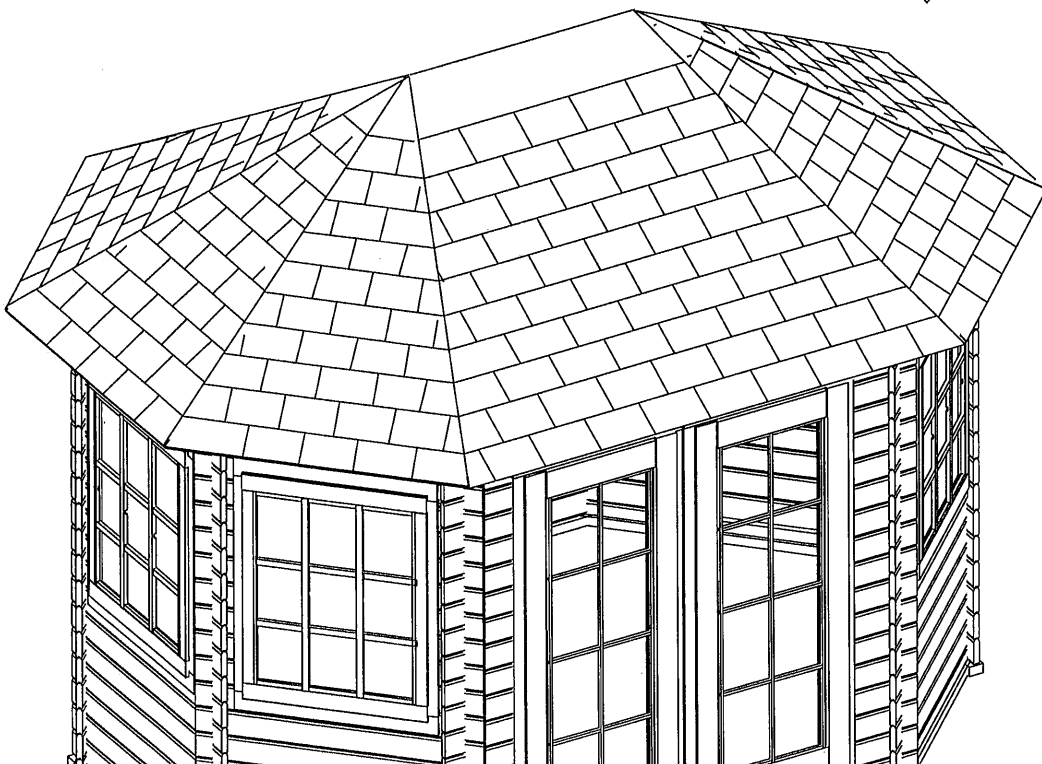
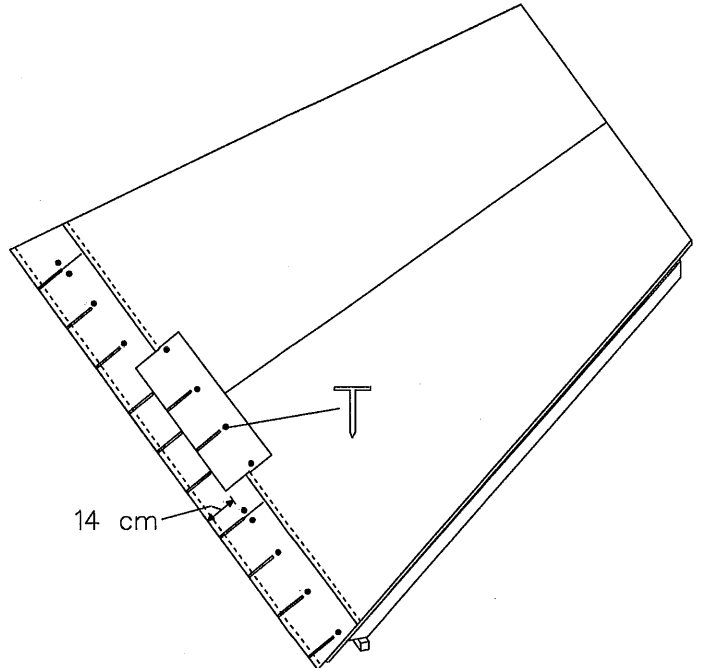
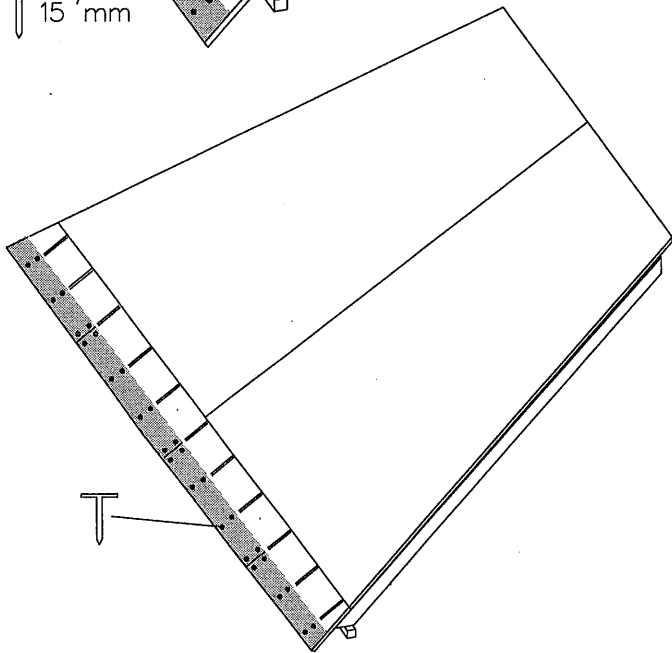
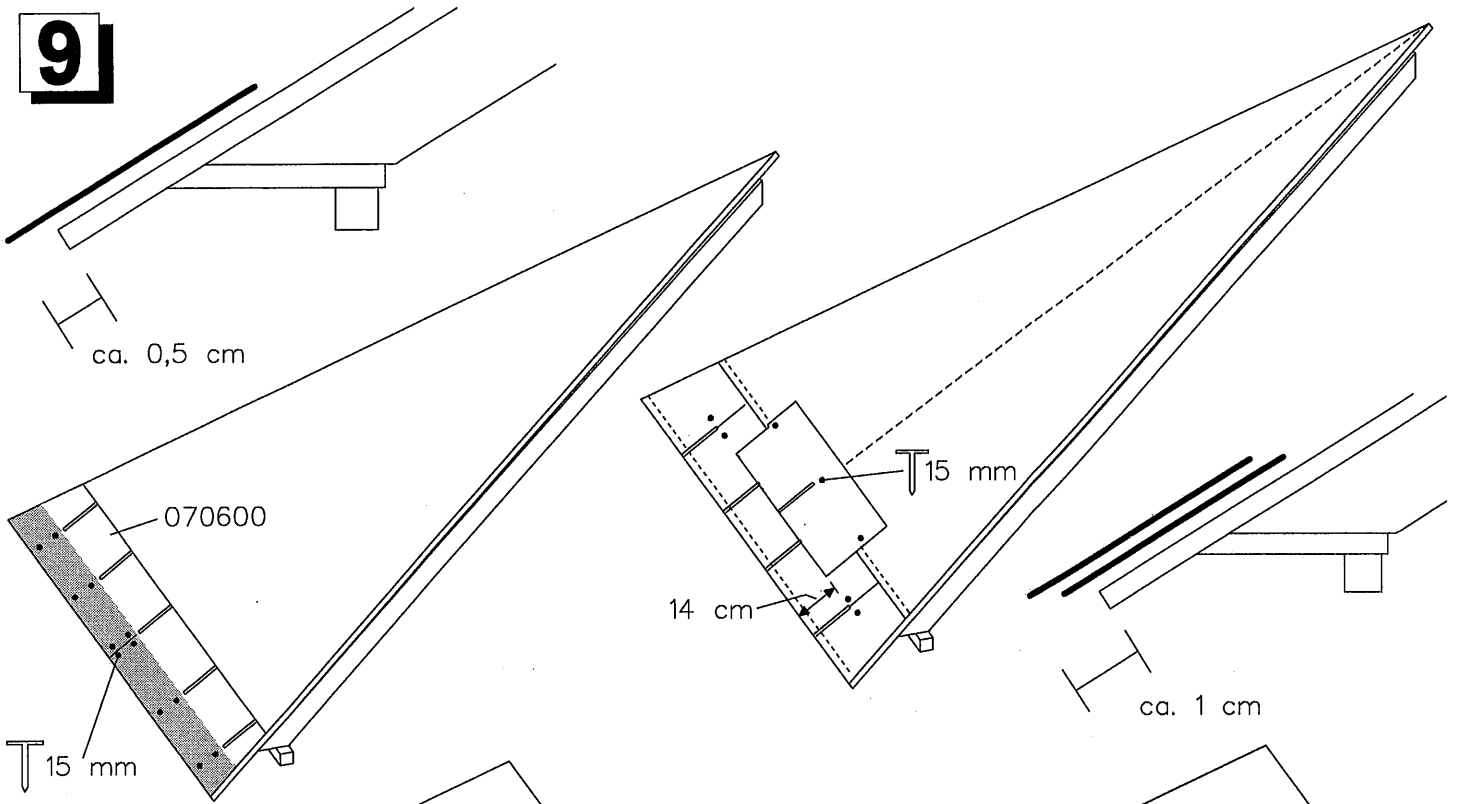

10

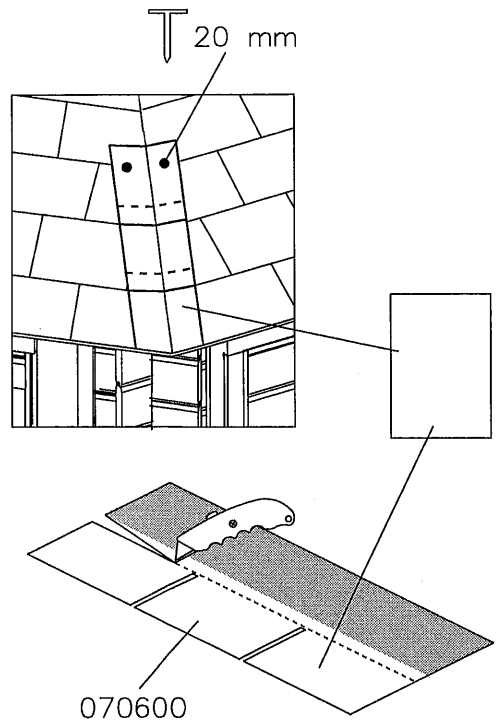
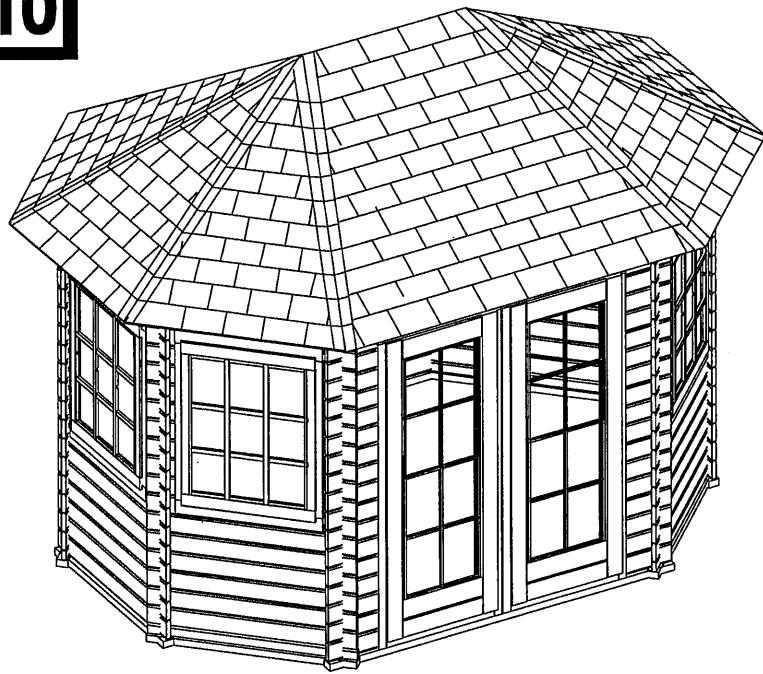

11

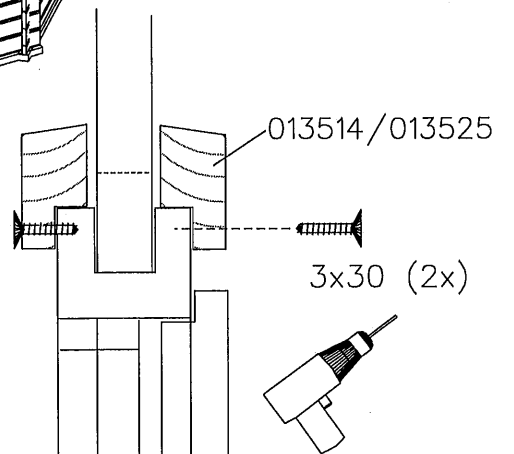
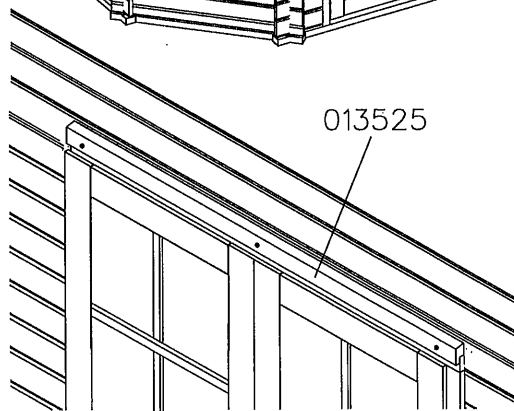
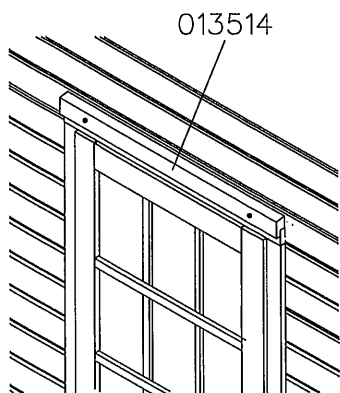
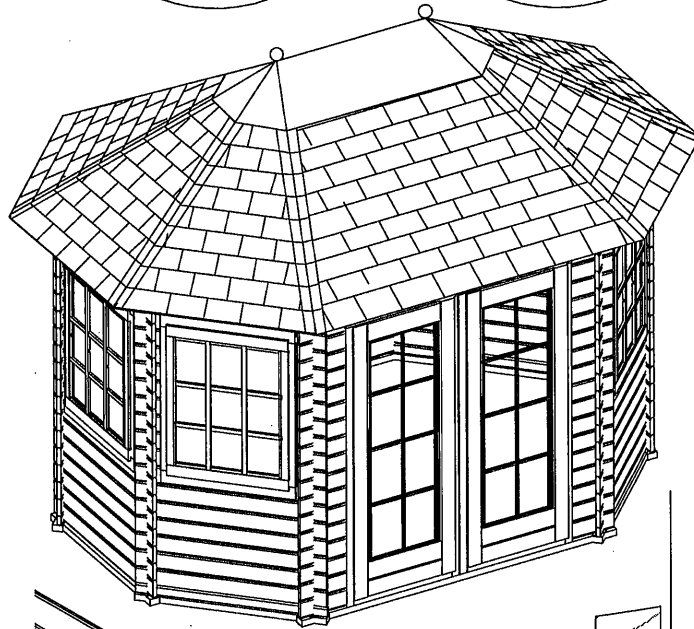
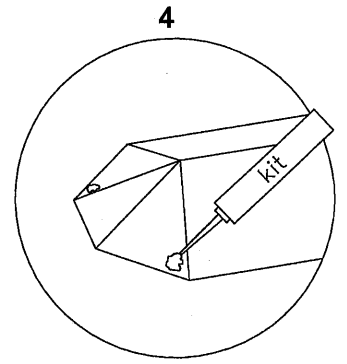
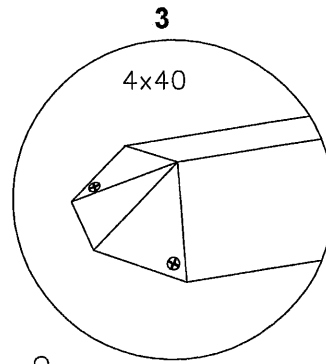
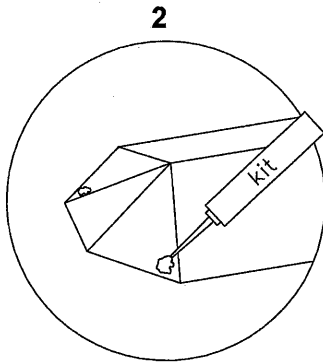
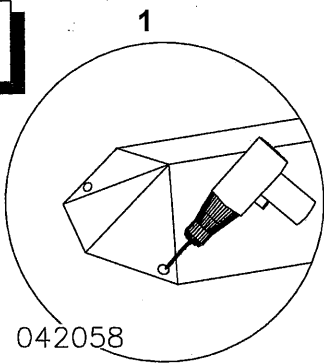

12

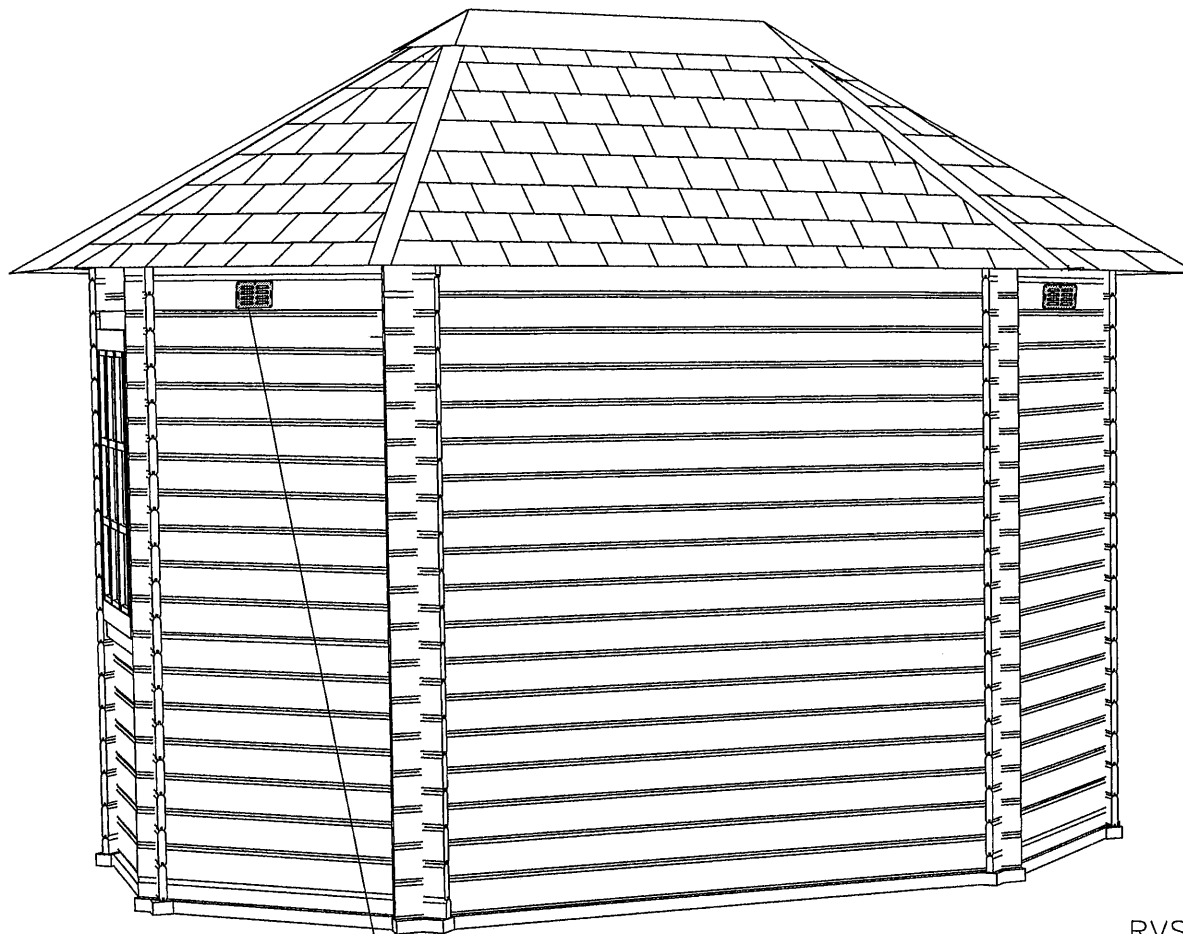

RVS 4x25

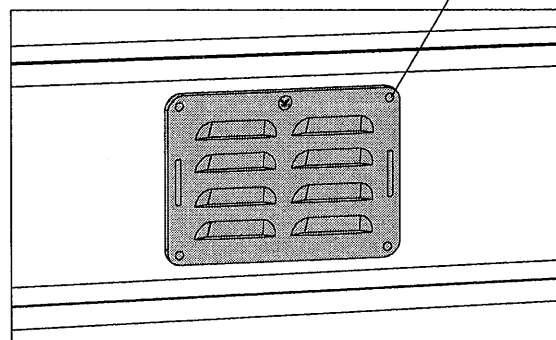
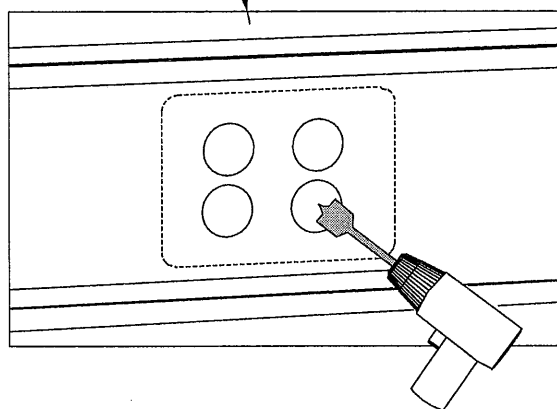

13

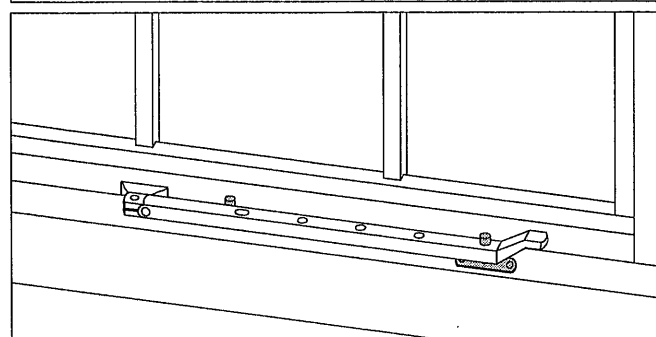
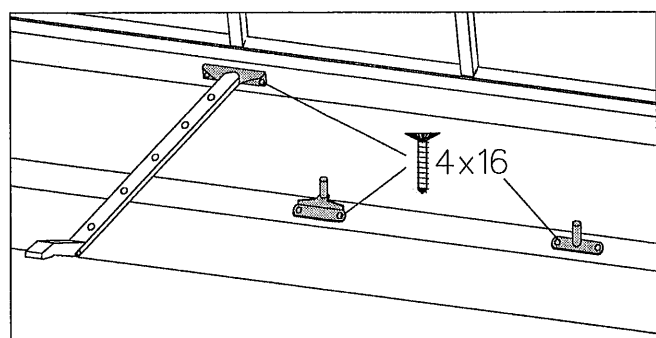
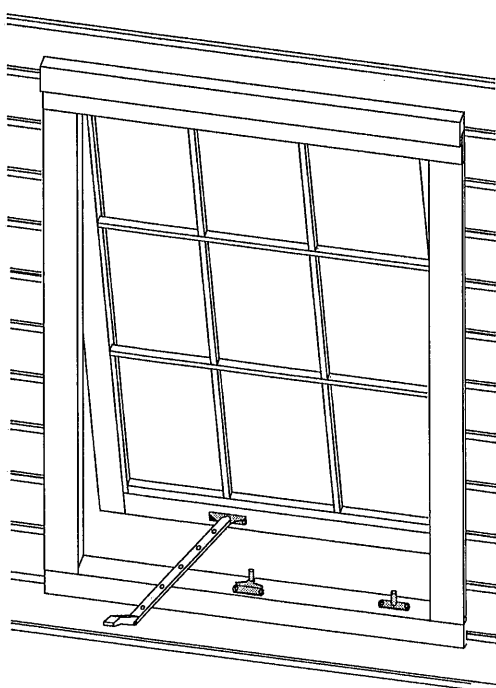

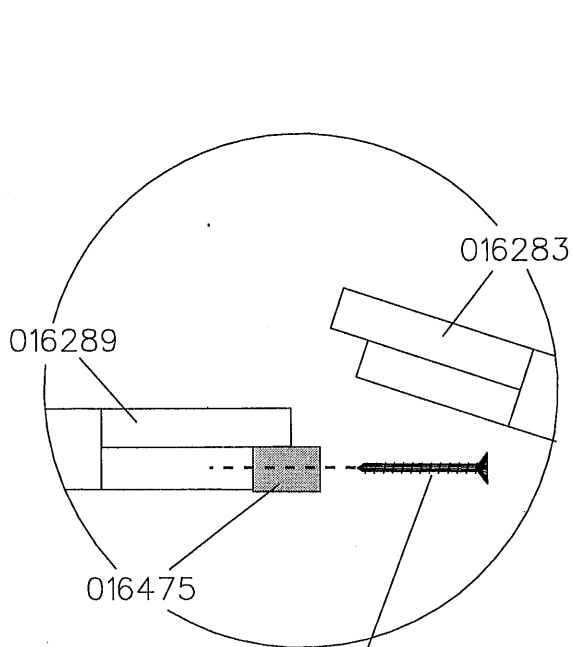
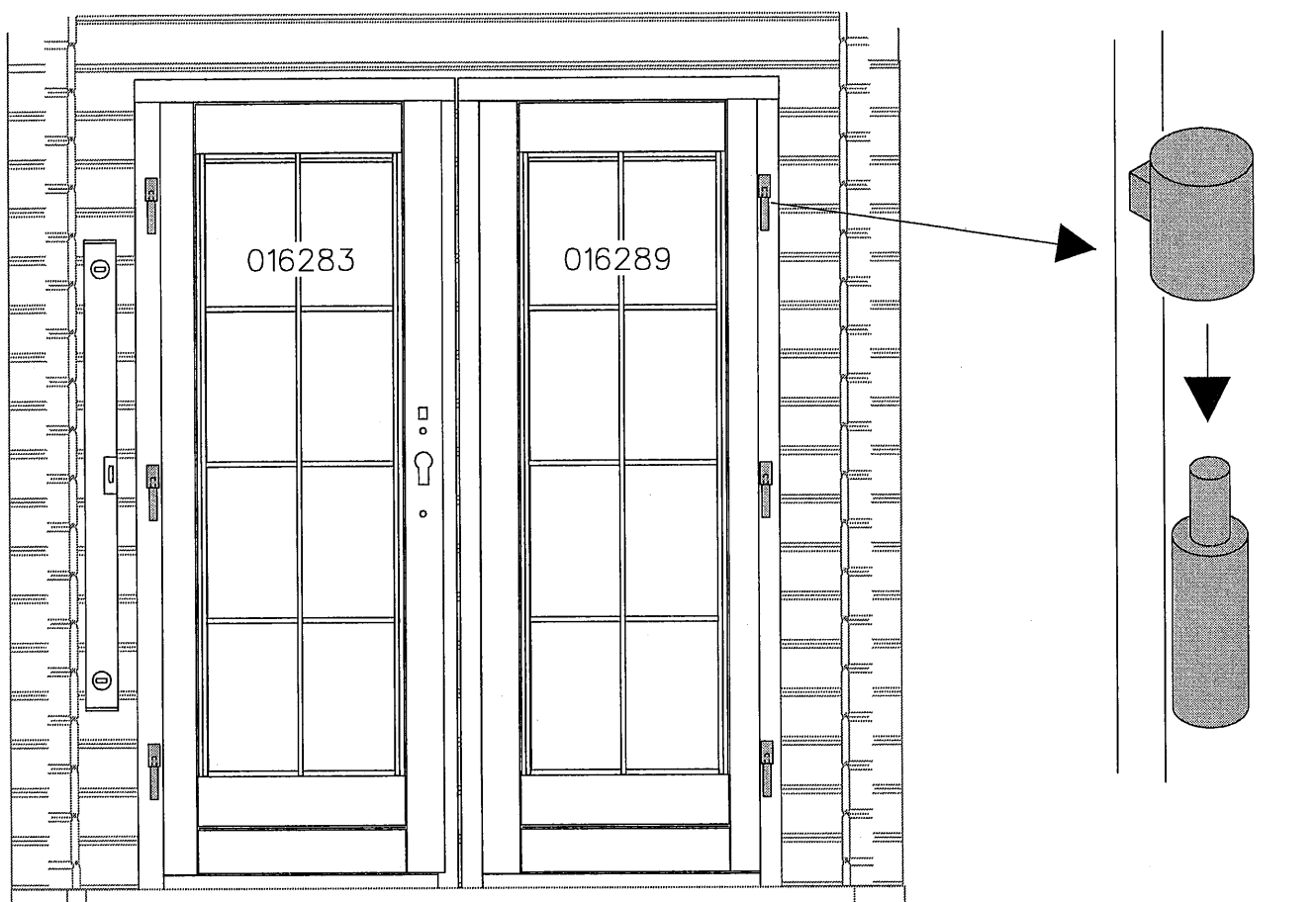

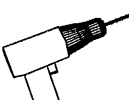
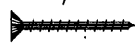
1. 
2. 4x60 

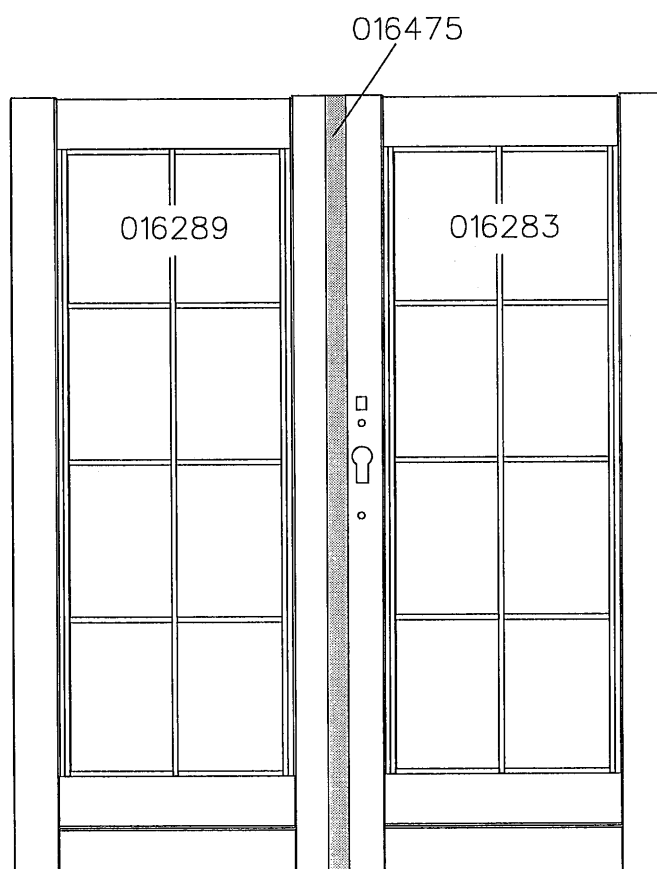

aanzicht binnenzijde * Innenansicht * vue côté facade
 inside-view * vista interna * vista interior

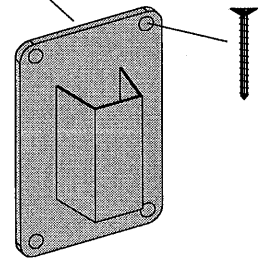
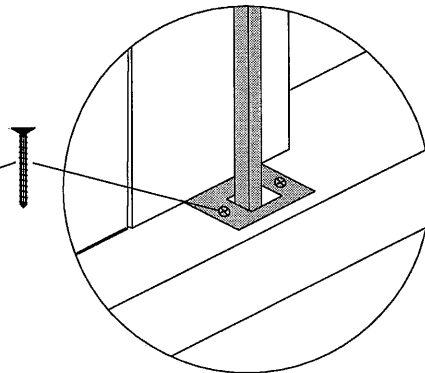
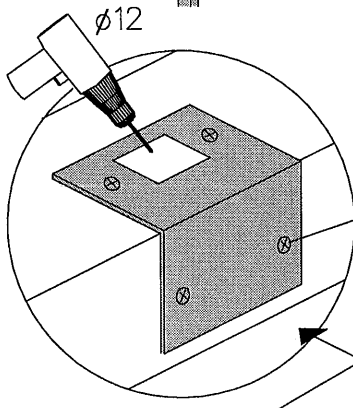
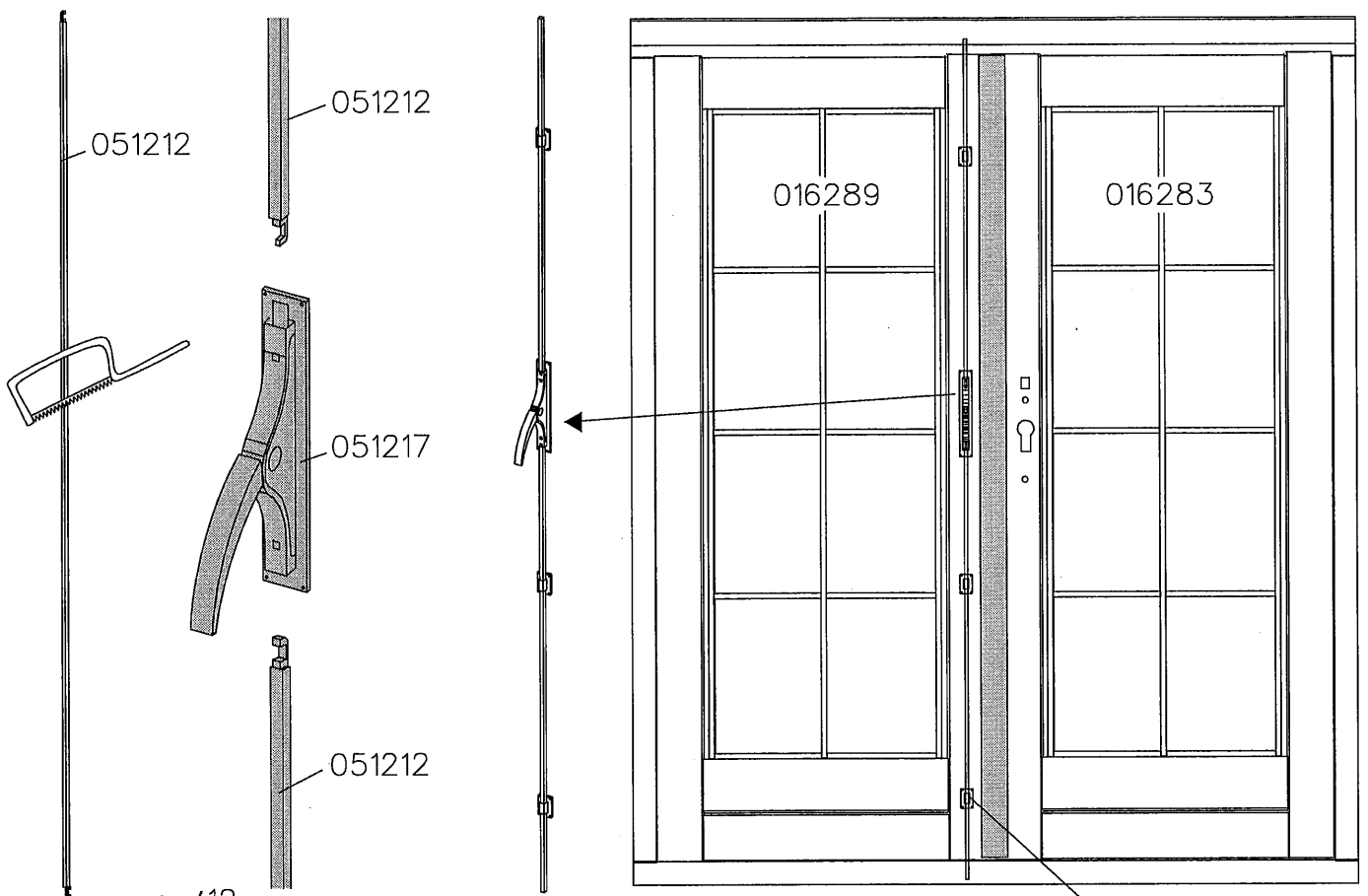

aanzicht buitenzijde Außenansicht
 vue côté extérieur outside-view
 vista esteriore vista exterior

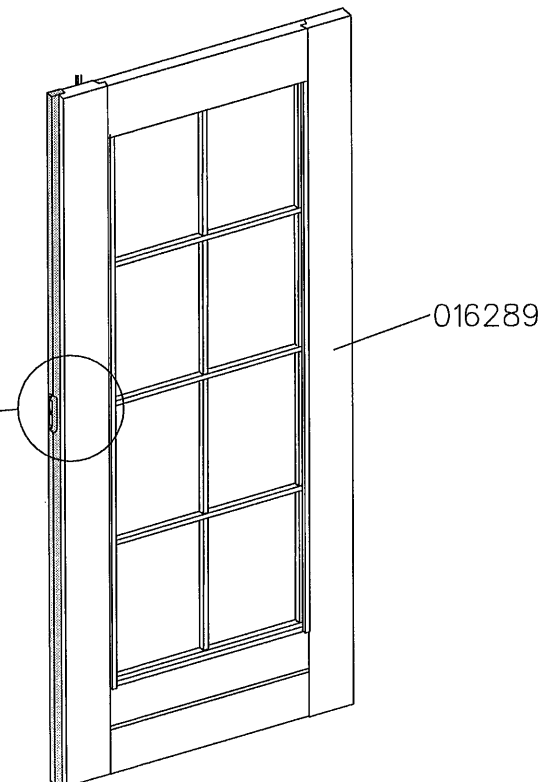
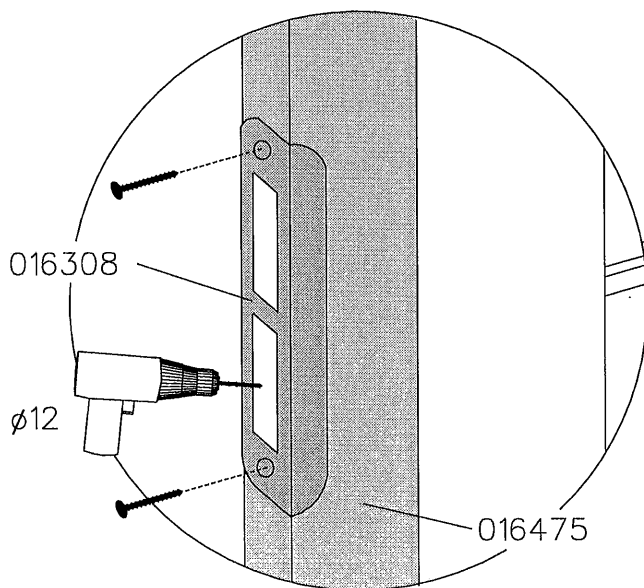

15

Vloer - Boden - Plancher - Floor - Pavimento - Suelo

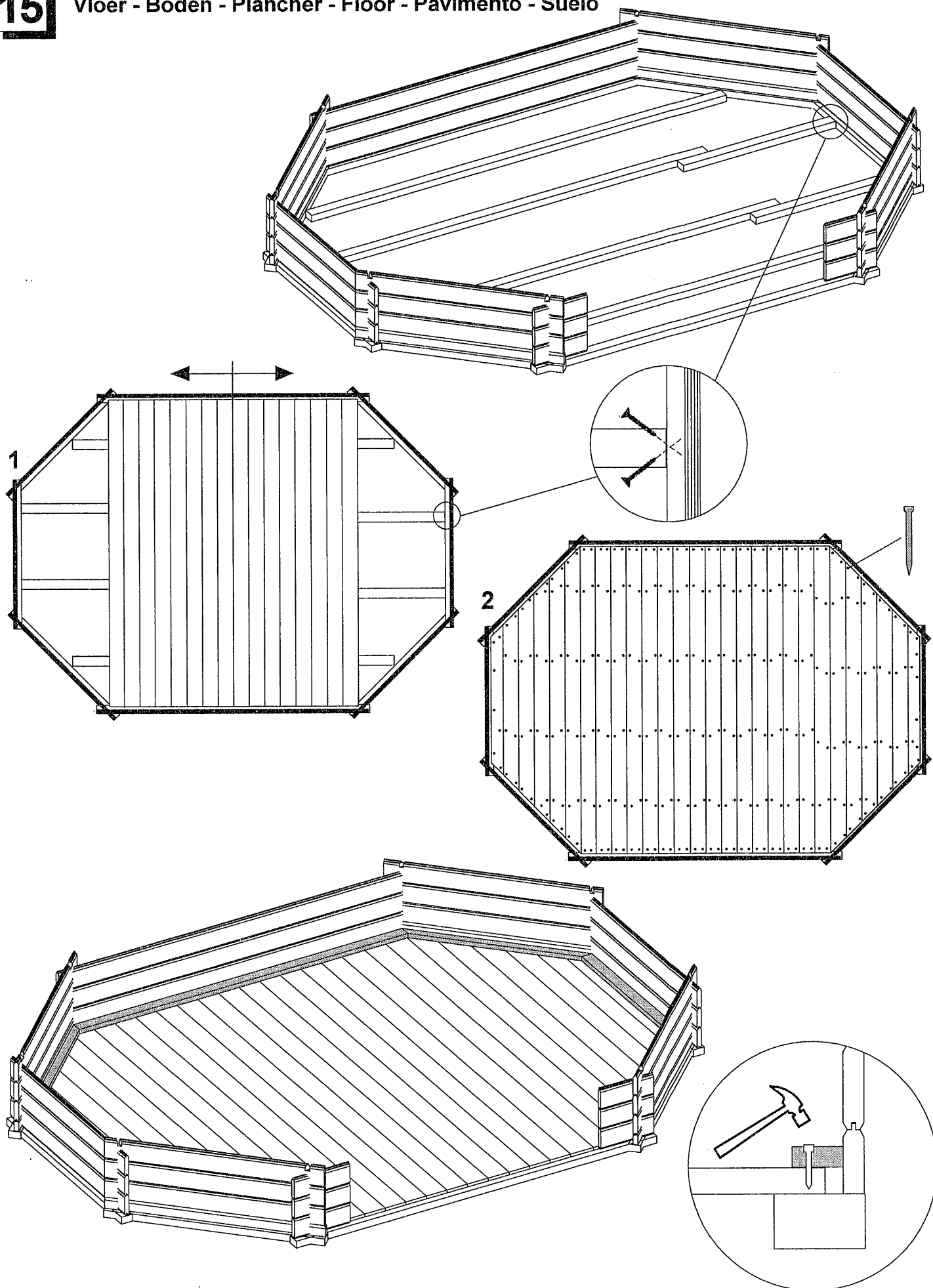



HillhouT

www.hillhout.com